

# 950L/962L

## Wheel Loaders



	950L	962L
Engine Model	Cat® C7.1 ACERT™	Cat C7.1 ACERT
Maximum Gross Power – ISO 14396	195 kW	195 kW
Maximum Net Power – ISO 9249	185 kW	185 kW
Bucket Capacities	2.7-4.4 m <sup>3</sup>	2.7-4.4 m <sup>3</sup>
Operating Weight	18 136 kg*	19 123 kg**

\*For 3.1 m<sup>3</sup> general purpose bucket with BOCE.

\*\*For 3.4 m<sup>3</sup> general purpose bucket with BOCE.

*The new 950L and 962L Wheel Loaders apply proven technologies systematically and strategically to meet your high expectations for reliability, productivity, fuel efficiency, and long service life.*



## **Contents**

Reliable .....	4
Durable .....	5
Productive .....	6
Fuel Efficient .....	7
Easy to Operate .....	8
Serviceable .....	9
Cat Connect Technology .....	10
Versatile .....	11
Owning Costs .....	12
Operating Costs .....	13
Specifications .....	14
Standard Equipment .....	27
Optional Equipment .....	28
Notes .....	29



## Reliability

- Cat C7.1 ACERT engine offers a combination of proven electronic, fuel and air systems and meets China Nonroad Stage III emission standards and U.S. EPA Tier 3/EU Stage IIIA equivalent emission standards.
- Utilizing rigorous component design and machine validation processes results in unmatched reliability, durability and high uptime.

## Durability

- Tough countershaft powershift transmission and axles handle extreme applications.
- Improved hydraulic hose routing reduces potential hose wear.
- Full flow hydraulic filtration system with additional loop filtration improves hydraulic system robustness and component life.

## Productivity

- Increased engine power improves machine performance and response.
- Lock-up clutch torque converter, combined with lock-to-lock shifting, delivers smooth shifts, fast acceleration and speed on grade.
- High capacity torque converter results in greater digging efficiency.
- Easy-to-load Performance Series Buckets feature a wider mouth and curved side plates that improve material retention (fill factor) and decrease cycle times.

## Fuel Efficiency

- Up to 10% lower fuel consumption than H Series.\*
- Power dense ACERT engine burns less fuel by providing power and torque when needed.

\*Actual results may vary based on factors such as, but not limited to, machine configuration, operator technique, machine application, climate, etc.

## Ease of Operation

- New best-in-class operator environment provides unmatched comfort, visibility, and efficiency.
- Intuitive, ergonomic controls keep operators focused on their work.

## Safety

- Excellent cab access with wide door and stair-like steps.
- Floor to ceiling windshield, large mirrors with integrated spot mirrors and rear vision camera provide industry leading all-around visibility.

## Serviceability

- One-piece tilting hood with side and rear doors; hydraulic and electrical service centers make access fast and easy.
- Safe ground level access to fuel fill, oil fill, filters and daily maintenance points means less servicing time required.

# Reliable

Proven components and technology  
you can count on.



## Caterpillar Designed Components

- Utilizing rigorous design and machine validation processes have delivered unmatched reliability, durability and high uptime for generations.
- Components used to build Cat wheel loaders are designed and manufactured to Caterpillar quality standards to ensure maximum performance even in extreme operating conditions.
- Heavy duty components reduce the risk of premature wear resulting in increased uptime and reduce operating costs over the lifetime of the machine.

## Equipment Monitoring

- Monitoring product health is key to maintaining reliability of any equipment.
- Cat Connect technologies (Product Link™, VisionLink®) take the guesswork out of equipment management.
- Many programs offered by your Cat dealer make tracking your machine health quick and easy.

## Renowned Cat Dealer Support

- Cat dealers provide the best support when it comes to servicing your machine increasing your uptime on the job site.
- Preventive maintenance programs like Scheduled Oil Sampling (S-O-S<sup>SM</sup>) analysis or comprehensive Customer Support Agreements help reduce lifetime maintenance costs.
- Best-in-class parts availability maximizes uptime.



**Durable**  
Better designed to meet your needs.

### **Power Train**

- Cat C7.1 engine with ACERT technology maintains engine performance, efficiency and durability.
- Tough countershaft powershift transmission and axles handle extreme applications effectively resulting in reliable performance and durable life.
- Front axle is rigidly mounted to the frame in order to withstand internal torque loads and still maintain support for the wheel loader.
- Rear axle can oscillate to  $\pm 13$  degrees helping to ensure all four wheels stay on the ground providing stability even in the roughest terrain, for excellent stability and traction.

### **Hydraulic System**

- Improved hydraulic hose routing reduces potential hose wear.
- Full flow hydraulic filtration system with additional loop filtration improves hydraulic system robustness and component life.

### **Linkage, Buckets and Frames**

- Proven Z-bar linkage with Performance Series Buckets offers excellent penetration into the pile, high breakout forces, good roll back angles and faster dig times resulting in improved tire life, superior fuel efficiency and exceptional production capabilities.
- Robotically welded two-piece structural frame design provides strong and rigid structures that absorb all the forces associated to penetration, loading and twisting.
- The L Series articulating hitch system, joins the front and rear frames, providing increased bearing force capacity.

# Productive

Work smart and move more.



## Engine

- Increased engine power in the 950L by approximately 22% and 8% in the 962L (compared to H series) improves machine performance and response.

## Transmission

- 5-speed transmission includes a lock up clutch torque converter, standard, that matches engine power and hydraulics to maximize machine performance and fuel efficiency.

## Performance Series Buckets

- Easy-to-load Performance Series Buckets feature wider mouth, longer floor and curved side plates that improve material retention (fill factor) and decrease cycle times.

## Dealer Support

- Your Cat dealer can help with operator training to help boost your productivity and profits.

## Fine-tuned technologies for the right applications

- Lock-up clutch torque converter, combined with lock-to-lock shifting, delivers smooth shifts, fast acceleration and speed on grade.
- High capacity torque converter results in greater digging efficiency.
- Z-bar linkage provides high breakout force at ground level in bucket applications.
- Optional high lift linkage offers increased hinge pin height to load more easily.
- Optional fully automatic traction control system (differential locks) improves performance in the pile and poor underfoot conditions while reducing tire wear with no operator intervention required.



# Fuel Efficient

Engineered to lower your operating costs.

## Engine and Emissions

- Cat C7.1 ACERT engine is designed for maximum fuel efficiency and increased power density, while meeting China Nonroad Stage III emission standards and Tier 3/Stage IIIA equivalent emission standards.
- Engine features innovative Cat electronics, fuel injection process, and air-management systems, reducing fuel consumption.

## Efficient Systems and Components

- Innovative systems intelligently lower average working engine speeds and reduce overall system heat loads resulting in significantly improved performance and fuel efficiency.

## Advanced Systems with Innovative Integration

- Deep system integration of new engine, power train, hydraulic system and cooling system result in lower fuel consumption on average compared to H Series.



- Up to 10% lower fuel consumption than H Series.\*
- Power dense ACERT engine burns less fuel by providing power and torque when needed.
- Performance Series Buckets feature a longer floor that easily digs through the pile resulting in lower fuel consumption.
- Productive Economy Mode provides maximum fuel savings with minimal productivity impact.
- Load sensing hydraulics result in proportional flow for implement and steering on demand.
- On-Demand Fan improves fuel efficiency, lower noise levels and reduced radiator plugging.
- Engine Idle Management System (EIMS) maximizes fuel efficiency by reducing engine rpm.
- Engine Idle Shutdown saves fuel and reduces hour accumulation on your machine.

\*Actual results may vary based on factors such as, but not limited to, machine configuration, operator technique, machine application, climate, etc.

# Easy to Operate

Safe. Comfortable. Efficient.



## Operator Environment

- New best-in-class operator environment features four post Roll Over Protection System (ROPS) cab providing unmatched comfort, visibility, and efficiency.
- Seat-mounted implement controls provide operators with precise control of the work tool, all while moving with the seat for maximum comfort.
- Low-effort steering wheel offers precise control in demanding operations.
- New, streamlined control panel includes easy to reach highly utilized machine controls increasing operator efficiency.
- Viscous cab mounts connect cab to frame of machine, decreasing noise and vibration resulting in a sustainable work environment and well-rested efficient, productive operator.
- Optional new ride control system with dual accumulators provides excellent ride quality and lowers cab vibrations.



## Safety

- Excellent cab access with wide door and stair-like steps.
- Floor to ceiling windshield, large mirrors with integrated spot mirrors and rear vision camera provide industry leading all-around visibility.
- Robust, repositioned grab bars provide safe access to machine platforms.
- Integrated rear vision camera enhances visibility behind machine helping operators work safely and productively.







# Serviceable

Easy to maintain. Easy to service.



## Engine Access

- One-piece tilting hood with side and rear doors makes access fast and easy.
- Best-in-class service access to engine, oil levels and coolant sight gauge means less servicing time required.

## Service Centers

- Electrical and hydraulic service centers provide grouped ground level access enhancing safety and convenience while reducing service time.
- Safe, ground level access to fuel fill, daily maintenance points and many filters means less servicing time required.



## Parking Brake

- External caliper disc parking brakes are easily accessible for inspection and service.

## Cooling System

- Cooling system is readily accessible for clean out and maintenance.
- Hydraulic and A/C cooler cores swing out providing easy access to both sides for cleaning.
- Access panel on left side of cooling package swings down to provide access to back side of engine coolant and Air-to-Air After Cooler (ATAAC).
- Optional variable pitch fan can automatically purge cooler cores by periodically reversing airflow when needed.





# Cat Connect Technology

Monitor, manage, and enhance job site operations.

## LINK Technologies

VisionLink enables owners to access data wirelessly to monitor machine health, utilization and location.

## PAYLOAD Technologies

Accurately weigh materials being loaded and hauled to improve productivity, reduce overloading, and track material movement.

### Cat Production Measurement (optional)

- Provides simple, accurate, on-the-go weighing to assist operators in delivering exact loads and working more efficiently.
- Intuitive user interface, within standard touch screen display, provides essential payload information in an easy-to-read, user-friendly format.
- Site managers can wirelessly access data via the VisionLink web portal to measure production and monitor efficiency.

## DETECT Technologies

Enhance operator awareness of the environment around working equipment and provide alerts to help keep people and assets safe.

### Rear Vision Camera

- Integrated rear vision camera enhances visibility behind machine.



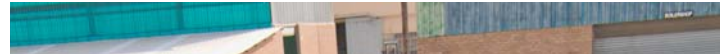

# Versatile

Do more jobs with one machine.



## Fusion™ Quick Coupler

### Improved Machine Performance

- Fusion Coupler System (patented) provides performance virtually identical to pin on – with all the flexibility of a quick coupler system.
- The Fusion Coupler sits back, close into the loader arms – minimizing offset and increasing the machine’s performance.

### No Loss of Performance

- Fusion is designed to integrate the work tool and the machine by pulling the coupler and tool closer into the loader which translates to increased lifting ability when compared to machines equipped with other coupler systems.

### Unsurpassed Durability

- Advanced wedging mechanism creates tight, rattle-free fit which eliminates play and wear – resulting in long service life.



## Performance Series Buckets

### Load Easy, Fuel Efficient, Carry More

- Buckets utilize a system based approach to balance bucket shape with machine’s linkage, weight, lift and tilt capacities.
- Reduced dig times and better material retention results in significant productivity and fuel efficiency improvements.

### Lower Operating Costs

- Buckets feature longer floor that easily digs through pile and provides excellent visibility for operators to see when bucket is full.
- Less time digging in the pile results in lower fuel consumption and improved tire life.
- Unique spill guard protects cab and linkage components from material overflow.

### Higher Productivity

- Buckets achieve higher fill factors – ranging from 100% to 115% depending on the machine application and material type due to curved side profile.

# Owning Costs

Proven best investment.



## Cat Product Link

- Cat Product Link allows remote monitoring of equipment to improve overall fleet management effectiveness.
- Product Link is deeply integrated into machine systems; information such as events, diagnostic codes, hours, fuel, idle time and other detailed information are transmitted to a secure web based application, VisionLink.
- VisionLink includes powerful tools to convey information to users and dealers, including mapping, working and idle time, fuel level and more.

## S-O-S Services

- Help manage component life and decrease machine downtime, increasing productivity and efficiency.
- Regular fluid sampling can help track what is going on inside your machine. Wear related problems are predictable and easily repairable.
- Maintenance can be done to accommodate your schedule, resulting in increased uptime and flexibility in maintenance repairs before failure.

## Parts Availability

- Caterpillar provides an unsurpassed level of personalized service to help you work more cost effectively and efficiently.
- By utilizing a worldwide parts network Cat dealers help minimize machine downtime and save money by fast delivery of replacement parts.

## Resale Value

- Caterpillar is not only known for machines that are better built, but provides product and dealer support to maintain the reliability and durability of your machine.



# Operating Costs

Save time and money by working smart.

## Most Fuel Efficient Machines in Industry

- Data from customer machines show Cat wheel loaders are the most fuel efficient machines in the industry.

## Engine, Hydraulics and Transmission

- Deep system integration results in more productivity, lower fuel consumption, without interrupting machine performance – making it seamless to you and your operators.

## Lock-up-Clutch Torque Converter and Shift Strategy

- Reduced torque interruption increases driveline efficiency, conserving fuel; auto 1-5 transmission mode keeps engine rpm low, reducing fuel consumption while delivering optimal machine performance.

## Performance Series Buckets

- Performance Series buckets deliver faster fill times and better material retention, ultimately reducing cycle times while improving productivity and fuel efficiency.

## Optional Automatic Traction Control (Differential Locks)

- Automatic traction control, with no operator intervention required, increases traction and reduces tire scuffing compared to other traction aids, further reducing your operating costs.

## External Caliper Disc Parking Brakes

- External caliper disc parking brakes do not have the inefficiencies of enclosed wet parking brakes due to brake discs running in oil nor is there any oil to change reducing fuel and maintenance costs.

# 950L/962L Wheel Loaders Specifications

## Engine – 950L

Engine Model	Cat C7.1 ACERT	
Maximum Gross Power (2,000 rpm)		
ISO 14396	195 kW	265 hp (metric)
Maximum Net Power (2,000 rpm)		
ISO 9249	185 kW	252 hp (metric)
Peak Gross Torque (1,400 rpm)		
ISO 14396	1050 N·m	
Maximum Net Torque (1,400 rpm)		
ISO 14396	984 N·m	
Bore	105 mm	
Stroke	135 mm	
Displacement	7.01 L	

- Cat engine with ACERT Technology – meets China Nonroad Stage III emission standards and Tier 3/Stage IIIA equivalent emission standards.
- The power ratings apply at the stated speed when tested under the reference conditions for the specified standards.
- The net power advertised is the power available at the flywheel when the engine is equipped with fan, alternator, air cleaner and aftertreatment.
- The gross power advertised is with the fan at maximum speed.

## Buckets – 950L

Bucket Capacities	2.7-4.4 m <sup>3</sup>
-------------------	------------------------

## Weight – 950L

Operating Weight	18 136 kg
------------------	-----------

- Weight based on a machine configuration with Michelin 23.5R25 XHA2 L3 radial tires, full fluids, operator, standard counterweight, cold start, roading fenders, Product Link, open/open axles (front/rear), power train guard, secondary steering, sound suppression and a 3.1 m<sup>3</sup> general purpose bucket with BOCE.

## Operating Specifications – 950L

Static Tipping Load – Full 40° Turn		
With Tire Deflection	10 926 kg	
No Tire Deflection	11 624 kg	
Breakout Force	152 kN	

- Full compliance to ISO (2007) 143971 Sections 1 thru 6, which requires 2% verification between calculations and testing.

## Engine – 962L

Engine Model	Cat C7.1 ACERT	
Maximum Gross Power (2,000 rpm)		
ISO 14396	195 kW	265 hp (metric)
Maximum Net Power (2,000 rpm)		
ISO 9249	185 kW	252 hp (metric)
Peak Gross Torque (1,400 rpm)		
ISO 14396	1050 N·m	
Maximum Net Torque (1,400 rpm)		
ISO 14396	984 N·m	
Bore	105 mm	
Stroke	135 mm	
Displacement	7.01 L	

- Cat engine with ACERT Technology – meets China Nonroad Stage III emission standards and Tier 3/Stage IIIA equivalent emission standards.
- The power ratings apply at the stated speed when tested under the reference conditions for the specified standards.
- The net power advertised is the power available at the flywheel when the engine is equipped with fan, alternator, air cleaner and aftertreatment.
- The gross power advertised is with the fan at maximum speed.

## Buckets – 962L

Bucket Capacities	2.7-4.4 m <sup>3</sup>
-------------------	------------------------

## Weight – 962L

Operating Weight	19 123 kg
------------------	-----------

- Weight based on a machine configuration with Michelin 23.5R25 XHA2 L3 radial tires, full fluids, operator, standard counterweight, cold start, roading fenders, Product Link, open/open axles (front/rear), power train guard, secondary steering, sound suppression and a 3.4 m<sup>3</sup> general purpose bucket with BOCE.

## Operating Specifications – 962L

Static Tipping Load – Full 40° Turn		
With Tire Deflection	11 700 kg	
No Tire Deflection	12 455 kg	
Breakout Force	146 kN	

- Full compliance to ISO (2007) 143971 Sections 1 thru 6, which requires 2% verification between calculations and testing.

# 950L/962L Wheel Loaders Specifications

## Transmission

Forward 1	6.9 km/h
Forward 2	12 km/h
Forward 3	19.3 km/h
Forward 4	25.7 km/h
Forward 5	39.5 km/h
Reverse 1	6.9 km/h
Reverse 2	12 km/h
Reverse 3	25.7 km/h

- Maximum travel speed in standard vehicle with empty bucket and standard L3 tires with 787 mm roll radius.

## Hydraulic System

Implement Pump Type	Variable axial piston
Implement System	
Maximum Pump Output (2,340 rpm) ( $\eta_{vol} = 95\%$ )	245 L/min
Maximum Operating Pressure	27 900 kPa
Optional 3rd/4th Function Maximum Flow	240 L/min
Optional 3rd/4th Function Maximum Pressure	21 780 kPa
Hydraulic Cycle Time with Rated Payload:	
Raise from Carry Position	5.3 Seconds
Dump, at Maximum Raise	1.4 Seconds
Lower, Empty, Float Down	2.8 Seconds
Total	9.5 Seconds

## Brakes– 950L

Brakes	Brakes meet ISO 3450 standards
--------	--------------------------------

## Axles – 950L

Front	Fixed
Rear	Oscillating $\pm 13$ degrees
Maximum Single-Wheel Rise and Fall	481 mm

## Cab

ROPS/FOPS	ROPS/FOPS meet ISO 3471 and ISO 3449 Level II standards
-----------	---

## Sound – 950L

The sound values indicated below are for specific operating conditions only. Machine and operator sound levels will vary at different engine and/or cooling fan speeds. Hearing protection may be needed when the machine is operated with a cabin that is not properly maintained, or when the doors and/or windows are open for extended periods or in a noisy environment.

With Cooling Fan Speed at Maximum Value:

Operator Sound Pressure Level (ISO 6396:2008)	72 dB(A)
Exterior Sound Power Level (ISO 6395:2008)	107 dB(A)
Exterior Sound Pressure Level (SAE J88:2013)	75 dB(A)*

With Cooling Fan Speed at 70% of Maximum Value:\*\*

Operator Sound Pressure Level (ISO 6396:2008)	69 dB(A)
Exterior Sound Power Level (ISO 6395:2008)	104 L <sub>WA</sub> ***

\*Distance of 15 m, moving forward in second gear ratio.

\*\*For machines in countries that adopt the “EU Directives.”

\*\*\*European Union Directives “2000/14/EC” as amended by “2005/88/EC.”

## Service Refill Capacities

Fuel Tank	275 L
Cooling System	58.6 L
Engine Crankcase	22 L
Transmission	43 L
Differentials and Final Drives – Front	43 L
Differentials and Final Drives – Rear	43 L
Hydraulic Tank	125 L

# 950L/962L Wheel Loaders Specifications

## 950L Dimensions

All dimensions are approximate.

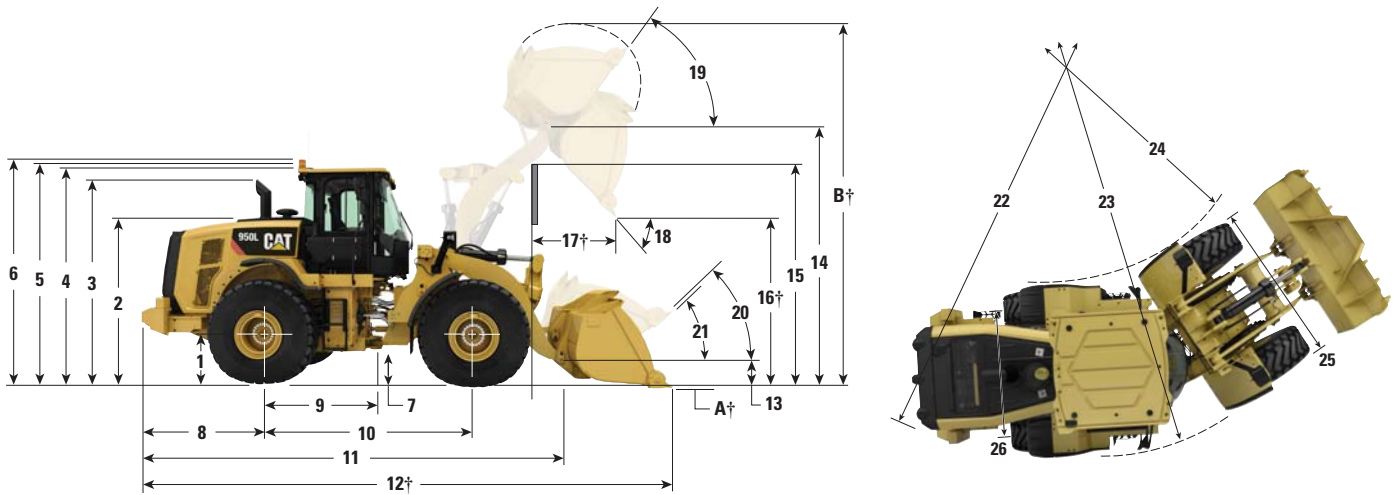

	Standard Lift	High Lift
1 Height to Axle Centerline	747 mm	747 mm
2 Height to Top of Hood	2697 mm	2697 mm
3 Height to Top of Exhaust Pipe	3415 mm	3415 mm
4 Height to Top of ROPS	3446 mm	3446 mm
5 Height to Top of Product Link Antenna	3477 mm	3477 mm
6 Height to Top of Warning Beacon	3747 mm	3747 mm
7 Ground Clearance	368 mm	368 mm
8 Center Line of Rear Axle to Edge of Counterweight	2083 mm	2071 mm
9 Center Line of Rear Axle to Hitch	1675 mm	1675 mm
10 Wheelbase	3350 mm	3350 mm
11 Overall Length (without bucket)	6939 mm	7428 mm
12 Shipping Length (with bucket level on ground)*†	8249 mm	8788 mm
13 Hinge Pin Height at Carry Height	663 mm	765 mm
14 Hinge Pin Height at Maximum Lift	3995 mm	4490 mm
15 Lift Arm Clearance at Maximum Lift	3410 mm	3794 mm
16 Dump Clearance at Maximum Lift and 45° Discharge*†	2856 mm	3351 mm
17 Reach at Maximum Lift and 45° Discharge*†	1319 mm	1387 mm
18 Dump Angle at Maximum Lift and Dump (on stops)*	53 degrees	50 degrees
19 Rack Back at Maximum Lift*	60 degrees	66 degrees
20 Rack Back at Carry Height*	49 degrees	54 degrees
21 Rack Back at Ground*	41 degrees	45 degrees
22 Clearance Circle (radius) to Counterweight	6026 mm	6027 mm
23 Clearance Circle (radius) to Outside of Tires	5984 mm	5984 mm
24 Clearance Circle (radius) to Inside of Tires	3218 mm	3218 mm
25 Width Over Tires (unloaded)	2814 mm	2814 mm
Width Over Tires (loaded)	2822 mm	2822 mm
26 Tread Width	2140 mm	2140 mm

\*With 3.1 m<sup>3</sup> general purpose pin on bucket with BOCE (see Operating Specifications for other Buckets).

†Dimensions are listed in Operating Specifications charts.

All height and tire related dimensions are with Michelin 23.5R25 XHA2 L3 radial tires (see Tire Option Chart for other tires).

“Width Over Tires” dimensions are over the bulge and include growth.



# 950L/962L Wheel Loaders Specifications

## 962L Dimensions

All dimensions are approximate.

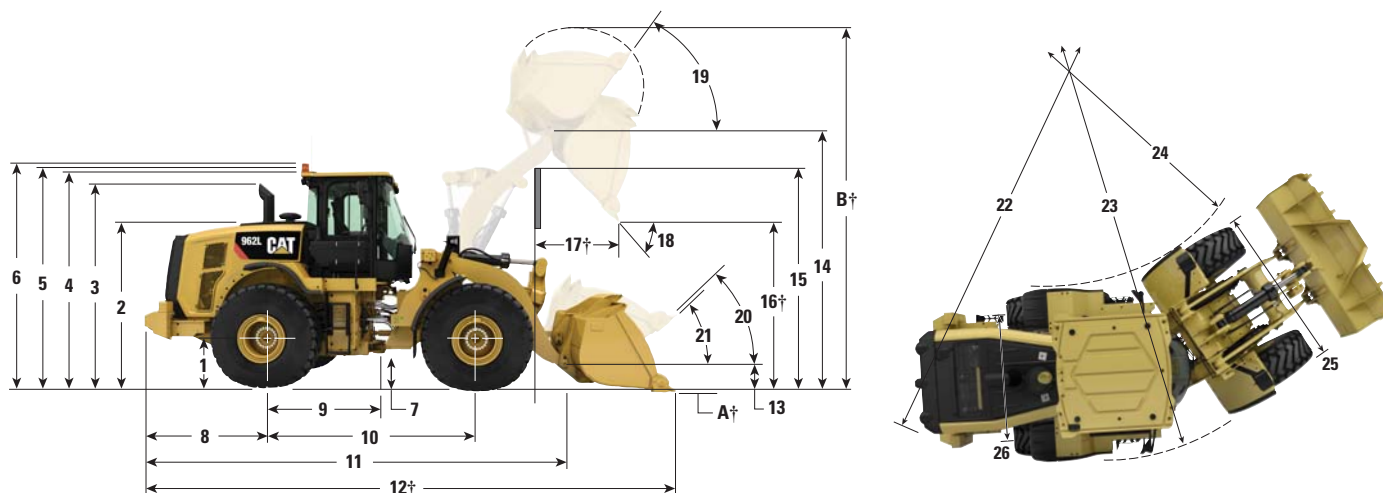

	Standard Lift	High Lift
1 Height to Axle Centerline	744 mm	744 mm
2 Height to Top of Hood	2694 mm	2694 mm
3 Height to Top of Exhaust Pipe	3412 mm	3412 mm
4 Height to Top of ROPS	3443 mm	3443 mm
5 Height to Top of Product Link Antenna	3474 mm	3474 mm
6 Height to Top of Warning Beacon	3744 mm	3744 mm
7 Ground Clearance	365 mm	365 mm
8 Center Line of Rear Axle to Edge of Counterweight	2147 mm	2186 mm
9 Center Line of Rear Axle to Hitch	1675 mm	1675 mm
10 Wheelbase	3350 mm	3350 mm
11 Overall Length (without bucket)	7129 mm	7543 mm
12 Shipping Length (with bucket level on ground)*†	8489 mm	8903 mm
13 Hinge Pin Height at Carry Height	642 mm	762 mm
14 Hinge Pin Height at Maximum Lift	4182 mm	4487 mm
15 Lift Arm Clearance at Maximum Lift	3624 mm	3791 mm
16 Dump Clearance at Maximum Lift and 45° Discharge*†	3007 mm	3312 mm
17 Reach at Maximum Lift and 45° Discharge*†	1299 mm	1416 mm
18 Dump Angle at Maximum Lift and Dump (on stops)*	52 degrees	49 degrees
19 Rack Back at Maximum Lift*	60 degrees	66 degrees
20 Rack Back at Carry Height*	49 degrees	54 degrees
21 Rack Back at Ground*	40 degrees	45 degrees
22 Clearance Circle (radius) to Counterweight	6024 mm	6066 mm
23 Clearance Circle (radius) to Outside of Tires	5984 mm	5984 mm
24 Clearance Circle (radius) to Inside of Tires	3218 mm	3218 mm
25 Width Over Tires (unloaded)	2821 mm	2821 mm
Width Over Tires (loaded)	2824 mm	2824 mm
26 Tread Width	2140 mm	2140 mm

\*With 3.4 m<sup>3</sup> general purpose pin on bucket with BOCE (see Operating Specifications for other Buckets).

†Dimensions are listed in Operating Specifications charts.

All height and tire related dimensions are with Michelin 23.5R25 XHA2 L3 radial tires (see Tire Option Chart for other tires).

“Width Over Tires” dimensions are over the bulge and include growth.

# 950L/962L Wheel Loaders Specifications

## 950L Tire Options

Tire Brand	Michelin	Bridgestone	Bridgestone	Michelin	Bridgestone	Michelin	Goodyear	Triangle	Titan	Flexport
Tire Size	23.5R25	23.5-25	23.5R25	750/ 65R25	23.5-25	23.5R25	23.5R25	23.5R25	725/ 70-25	65×13×25 (23.5×25)
Tread Type	L-3	L-3	L-3	L-3	L-3	L-5	L-3	L-3	L-4	—
Tread Pattern	XHA2	SRG LD	VJT	XLD	VL2	XLD D2	RT-3B	TB516	LS150	Smooth
Width over Tires – Maximum (unloaded)*	2814 mm	2768 mm	2798 mm	2948 mm	2769 mm	2817 mm	2835 mm	2770 mm	2896 mm	2808 mm
Width over Tires – Maximum (loaded)*	2822 mm	2795 mm	2831 mm	2965 mm	2782 mm	2833 mm	2846 mm	2821 mm	2860 mm	2821 mm
Change in Vertical Dimensions (average of front and rear)	0 mm	1 mm	-6 mm	-6 mm	14 mm	28 mm	-1 mm	13 mm	29 mm	45 mm
Change in Horizontal Reach	0 mm	-16 mm	6 mm	11 mm	3 mm	-25 mm	3.4 mm	-3.0 mm	-30 mm	-10 mm
Change in Clearance Circle to Outside of Tires	0 mm	-27 mm	9 mm	143 mm	-40 mm	5 mm	24 mm	-0.9 mm	38.1 mm	-1 mm
Change in Clearance Circle to Inside of Tires	0 mm	27 mm	-9 mm	-143 mm	40 mm	-5 mm	-24 mm	1 mm	-38 mm	1 mm
Change in Operating Weight (without Ballast)	0 kg	-248 kg	168 kg	801 kg	-100 kg	668 kg	127 kg	-251 kg	339 kg	4312 kg

\*Width over tire bulge and includes tire growth.

## Changes Specific to the 950L

Tire Brand	Michelin	Bridgestone	Bridgestone	Michelin	Bridgestone	Michelin	Goodyear	Triangle	Titan	Flexport
Tire Size	23.5R25	23.5-25	23.5R25	750/ 65R25	23.5-25	23.5R25	23.5R25	23.5R25	725/ 70-25	65×13×25 (23.5×25)
Tread Type	L-3	L-3	L-3	L-3	L-3	L-5	L-3	L-3	L-4	—
Tread Pattern	XHA2	SRG LD	VJT	XLD	VL2	XLD D2	RT-3B	TB516	LS150	Smooth
Change in Static Tipping Load – Straight	0 kg	-165 kg	112 kg	534 kg	-67 kg	446 kg	85 kg	-167 kg	226 kg	2876 kg
Change in Static Tipping Load – Articulated	0 kg	-144 kg	98 kg	466 kg	-58 kg	389 kg	74 kg	-146 kg	197 kg	2508 kg

# 950L/962L Wheel Loaders Specifications

## 962L Tire Options

Tire Brand	Michelin	Bridgestone	Bridgestone	Bridgestone	Michelin	Bridgestone	Michelin	Goodyear	Triangle	Titan	Flexport
Tire Size	23.5R25	23.5R25	23.5-25	23.5R25	750/65R25	23.5-25	23.5R25	23.5R25	23.5R25	725/70-25	65×13×25 (23.5×25)
Tread Type	L-3	L-3	L-3	L-3	L-3	L-3	L-5	L-3	L-3	L-4	—
Tread Pattern	XHA2	VMT	SRG LD	VJT	XLD	VL2	XLD D2	RT-3B	TB516	LS150	Smooth
Width over Tires – Maximum (unloaded)*	2821 mm	2810 mm	2768 mm	2809 mm	2954 mm	2771 mm	2825 mm	2840 mm	2768 mm	2921 mm	2798 mm
Width over Tires – Maximum (loaded)*	2824 mm	2835 mm	2797 mm	2832 mm	2967 mm	2784 mm	2835 mm	2847 mm	2828 mm	2855 mm	2820 mm
Change in Vertical Dimensions (average of front and rear)	0 mm	-2 mm	1 mm	-6 mm	-6 mm	16 mm	28 mm	1 mm	15 mm	32 mm	48 mm
Change in Horizontal Reach	0 mm	6 mm	-16 mm	6 mm	11 mm	3 mm	-25 mm	3.4 mm	-3 mm	-30.0 mm	-10 mm
Change in Clearance Circle to Outside of Tires	0 mm	12 mm	-27 mm	9 mm	143 mm	-40 mm	11 mm	23.2 mm	4.3 mm	30.8 mm	-4 mm
Change in Clearance Circle to Inside of Tires	0 mm	-12 mm	27 mm	-9 mm	-143 mm	40 mm	-11 mm	-23 mm	-4 mm	-31 mm	4 mm
Change in Operating Weight (without Ballast)	0 kg	188 kg	-248 kg	168 kg	801 kg	-100 kg	668 kg	127 kg	-251 kg	339 kg	4312 kg

\*Width over tire bulge and includes tire growth.

## Changes Specific to the 962L

Tire Brand	Michelin	Bridgestone	Bridgestone	Bridgestone	Michelin	Bridgestone	Michelin	Goodyear	Triangle	Titan	Flexport
Tire Size	23.5R25	23.5R25	23.5-25	23.5R25	750/65R25	23.5-25	23.5R25	23.5R25	23.5R25	725/70-25	65×13×25 (23.5×25)
Tread Type	L-3	L-3	L-3	L-3	L-3	L-3	L-5	L-3	L-3	L-4	—
Tread Pattern	XHA2	VMT	SRG LD	VJT	XLD	VL2	XLD D2	RT-3B	TB516	LS150	Smooth
Change in Static Tipping Load – Straight	0 kg	119 kg	-157 kg	106 kg	507 kg	-63 kg	423 kg	81 kg	-159 kg	215 kg	2729 kg
Change in Static Tipping Load – Articulated	0 kg	104 kg	-137 kg	93 kg	442 kg	-55 kg	368 kg	70 kg	-138 kg	187 kg	2378 kg

# 950L/962L Wheel Loaders Specifications

## 950L Bucket Fill Factors and Selection Chart

The bucket size must be chosen based on the density of the material and on the expected fill factor. The new Cat Performance Series Buckets with longer floor, larger bucket opening, increased repository angle, rounded side boards and integrated spill guard, demonstrate fill factors significantly higher than previous generation or non Cat buckets. The actual volume handled by the machine is thus often larger than the rated capacity.

Loose Material		Material Density	Fill Factor (%)*
Earth/Clay		1500-1700 kg/m <sup>3</sup>	115
Sand and Gravel		1500-1700 kg/m <sup>3</sup>	115
Aggregate:	25-76 mm	1600-1700 kg/m <sup>3</sup>	110
	19 mm and smaller	1800 kg/m <sup>3</sup>	105
Rock:	76 mm and larger	1600 kg/m <sup>3</sup>	100

\*As a % of ISO rated capacity.

**Note:** Fill Factors achieved will also depend on whether the product is washed or not washed.

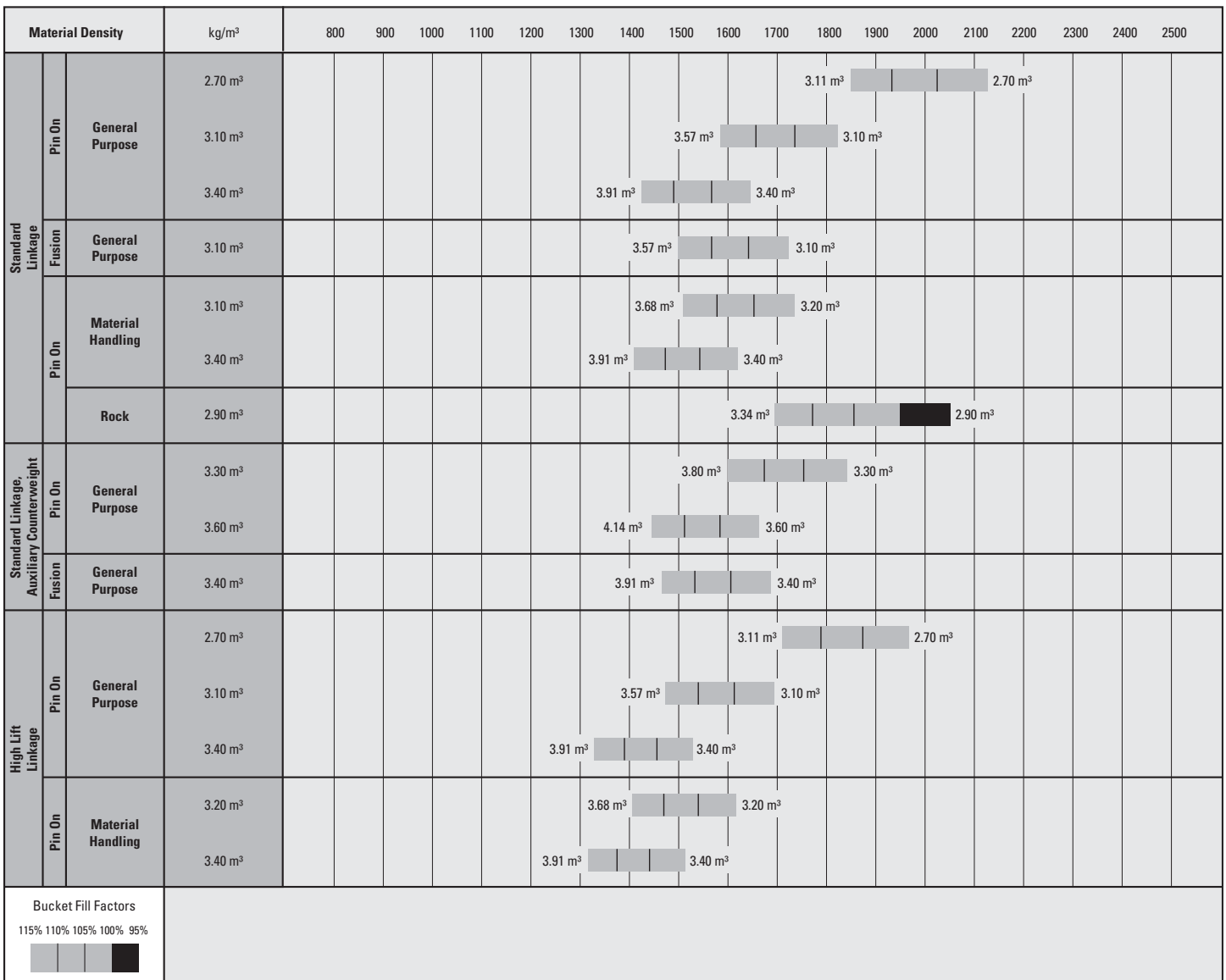

**Note:** All buckets are showing Bolt-on Edges except the Rock Bucket is showing Tips.

# 950L/962L Wheel Loaders Specifications

## 950L Operating Specifications with Buckets

Linkage	Standard Linkage						High Lift Linkage Change*
Bucket Type	General Purpose – Pin On						
Edge Type	Bolt-On Cutting Edges	Bolt-On Cutting Edges	Teeth and Segments	Bolt-On Cutting Edges	Teeth and Segments		
Capacity – Rated	m <sup>3</sup>	2.70	3.10	3.10	3.40	3.40	
Capacity – 110%	m <sup>3</sup>	2.97	3.41	3.41	3.74	3.74	
Width	mm	2927	2927	2994	2927	2994	
<b>16</b> † Dump Clearance at Maximum Lift and 45° Discharge	mm	2936	2856	2738	2791	2672	495
<b>17</b> † Reach at Maximum Lift and 45° Discharge	mm	1263	1319	1430	1371	1481	67
Reach at Level Lift Arm and Bucket Level	mm	2527	2627	2788	2712	2873	405
<b>A</b> † Digging Depth	mm	89	89	89	89	89	21
<b>12</b> † Overall Length	mm	7969	8069	8243	8154	8328	652
<b>B</b> † Overall Height with Bucket at Maximum Lift	mm	5363	5325	5325	5529	5529	496
Loader Clearance Circle Radius with Bucket at Carry Position	mm	6651	6678	6760	6702	6784	391
Static Tipping Load, Straight (ISO)**	kg	12 804	12 621	12 481	12 463	12 322	-776
Static Tipping Load, Straight (Rigid Tire)**	kg	13 492	13 314	13 173	13 159	13 017	-854
Static Tipping Load, Articulated (ISO)**	kg	11 099	10 926	10 786	10 776	10 635	-780
Static Tipping Load, Articulated (Rigid Tire)**	kg	11 793	11 624	11 483	11 478	11 335	-845
Breakout Force	kN	166	152	151	141	140	-8
Operating Weight	kg	18 047	18 136	18 244	18 211	18 319	1137

† Illustration shown with Dimension charts.

\* Maximum values.

\*\* Static tipping loads and operating weights shown are based on a global machine configuration with Michelin 23.5R25 XHA2 L3 radial tires, full fluids, operator, standard counterweight, cold start, roading fenders, Product Link, open/open axles (front/rear), power train guard, secondary steering, sound suppression.

(ISO) Full compliance to ISO 14397-1 (2007) Sections 1 thru 6, which requires 2% verification between calculations and testing.

(Rigid Tire) Compliance to ISO 14397-1 (2007) Sections 1 thru 5.

Other buckets are available and offerings vary by region. Consult your local Cat dealer for further details.

# 950L/962L Wheel Loaders Specifications

## 950L Operating Specifications with Buckets

Linkage		Standard Linkage				High Lift Linkage	High Lift Linkage Change*
Bucket Type		General Purpose – Fusion QC		Material Handling – Pin On		Material Handling – Pin On	
Edge Type		Bolt-On Cutting Edges	Teeth and Segments	Bolt-On Cutting Edges	Teeth and Segments	Bolt-On Cutting Edges	
Capacity – Rated	m <sup>3</sup>	3.10	3.10	3.40	3.40	3.40	
Capacity – 110%	m <sup>3</sup>	3.41	3.41	3.74	3.74	3.74	
Width	mm	2927	2994	2927	2994	2927	
<b>16</b> † Dump Clearance at Maximum Lift and 45° Discharge	mm	2814	2697	2721	2596	3216	495
<b>17</b> † Reach at Maximum Lift and 45° Discharge	mm	1355	1467	1291	1393	1359	67
Reach at Level Lift Arm and Bucket Level	mm	2682	2843	2722	2883	3128	405
<b>A</b> † Digging Depth	mm	97	97	97	97	119	21
<b>12</b> † Overall Length	mm	8130	8304	8170	8344	8821	652
<b>B</b> † Overall Height with Bucket at Maximum Lift	mm	5468	5468	5539	5539	6035	496
Loader Clearance Circle Radius with Bucket at Carry Position	mm	6693	6776	6708	6790	6903	391
Static Tipping Load, Straight (ISO)**	kg	12 009	11 870	12 321	12 181	11 622	-776
Static Tipping Load, Straight (Rigid Tire)**	kg	12 689	12 548	13 002	12 860	12 235	-854
Static Tipping Load, Articulated (ISO)**	kg	10 340	10 201	10 652	10 511	9941	-780
Static Tipping Load, Articulated (Rigid Tire)**	kg	11 026	10 885	11 339	11 197	10 572	-845
Breakout Force	kN	145	143	140	139	132	-8
Operating Weight	kg	18 614	18 722	18 216	18 324	19 353	1137

† Illustration shown with Dimension charts.

\* Maximum values.

\*\* Static tipping loads and operating weights shown are based on a global machine configuration with Michelin 23.5R25 XHA2 L3 radial tires, full fluids, operator, standard counterweight, cold start, roading fenders, Product Link, open/open axles (front/rear), power train guard, secondary steering, sound suppression.

(ISO) Full compliance to ISO 14397-1 (2007) Sections 1 thru 6, which requires 2% verification between calculations and testing.

(Rigid Tire) Compliance to ISO 14397-1 (2007) Sections 1 thru 5.

Other buckets are available and offerings vary by region. Consult your local Cat dealer for further details.

# 950L/962L Wheel Loaders Specifications

## 950L Operating Specifications with Buckets – Auxiliary Counterweight

Package		Auxiliary Counterweight			High Lift Linkage Change*
Bucket Type		General Purpose – Pin On		General Purpose – Fusion QC	
Edge Type		Bolt-On Cutting Edges	Bolt-On Cutting Edges	Bolt-On Cutting Edges	
Capacity – Rated	m <sup>3</sup>	3.30	3.60	3.40	
Capacity – 110%	m <sup>3</sup>	3.63	3.96	3.74	
Width	mm	2927	2927	2927	
<b>16</b> † Dump Clearance at Maximum Lift and 45° Discharge	mm	2817	2745	2749	495
<b>17</b> † Reach at Maximum Lift and 45° Discharge	mm	1349	1407	1407	67
Reach at Level Lift Arm and Bucket Level	mm	2677	2772	2767	405
<b>A</b> † Digging Depth	mm	89	89	97	21
<b>12</b> † Overall Length	mm	8269	8364	8365	652
<b>B</b> † Overall Height with Bucket at Maximum Lift	mm	5500	5587	5548	496
Loader Clearance Circle Radius with Bucket at Carry Position	mm	6692	6718	6717	391
Static Tipping Load, Straight (ISO)**	kg	13 611	13 425	12 924	-776
Static Tipping Load, Straight (Rigid Tire)**	kg	14 382	14 201	13 682	-854
Static Tipping Load, Articulated (ISO)**	kg	11 733	11 558	11 078	-780
Static Tipping Load, Articulated (Rigid Tire)**	kg	12 513	12 342	11 846	-845
Breakout Force	kN	146	135	135	-8
Operating Weight	kg	18 680	18 768	19 189	1137

† Illustration shown with Dimension charts.

\* Maximum values.

\*\* Static tipping loads and operating weights shown are based on a global machine configuration with Michelin 23.5R25 XHA2 L3 radial tires, full fluids, operator, standard counterweight, cold start, roading fenders, Product Link, open/open axles (front/rear), power train guard, secondary steering, sound suppression.

(ISO) Full compliance to ISO 14397-1 (2007) Sections 1 thru 6, which requires 2% verification between calculations and testing.

(Rigid Tire) Compliance to ISO 14397-1 (2007) Sections 1 thru 5.

Other buckets are available and offerings vary by region. Consult your local Cat dealer for further details.

# 950L/962L Wheel Loaders Specifications

## 962L Bucket Fill Factors and Selection Chart

The bucket size must be chosen based on the density of the material and on the expected fill factor. The new Cat Performance Series Buckets with longer floor, larger bucket opening, increased repository angle, rounded side boards and integrated spill guard, demonstrate fill factors significantly higher than previous generation or non Cat buckets. The actual volume handled by the machine is thus often larger than the rated capacity.

Loose Material		Material Density	Fill Factor (%)*
Earth/Clay		1500-1700 kg/m <sup>3</sup>	115
Sand and Gravel		1500-1700 kg/m <sup>3</sup>	115
Aggregate:	25-76 mm	1600-1700 kg/m <sup>3</sup>	110
	19 mm and smaller	1800 kg/m <sup>3</sup>	105
Rock:	76 mm and larger	1600 kg/m <sup>3</sup>	100

\*As a % of ISO rated capacity.

**Note:** Fill Factors achieved will also depend on whether the product is washed or not washed.

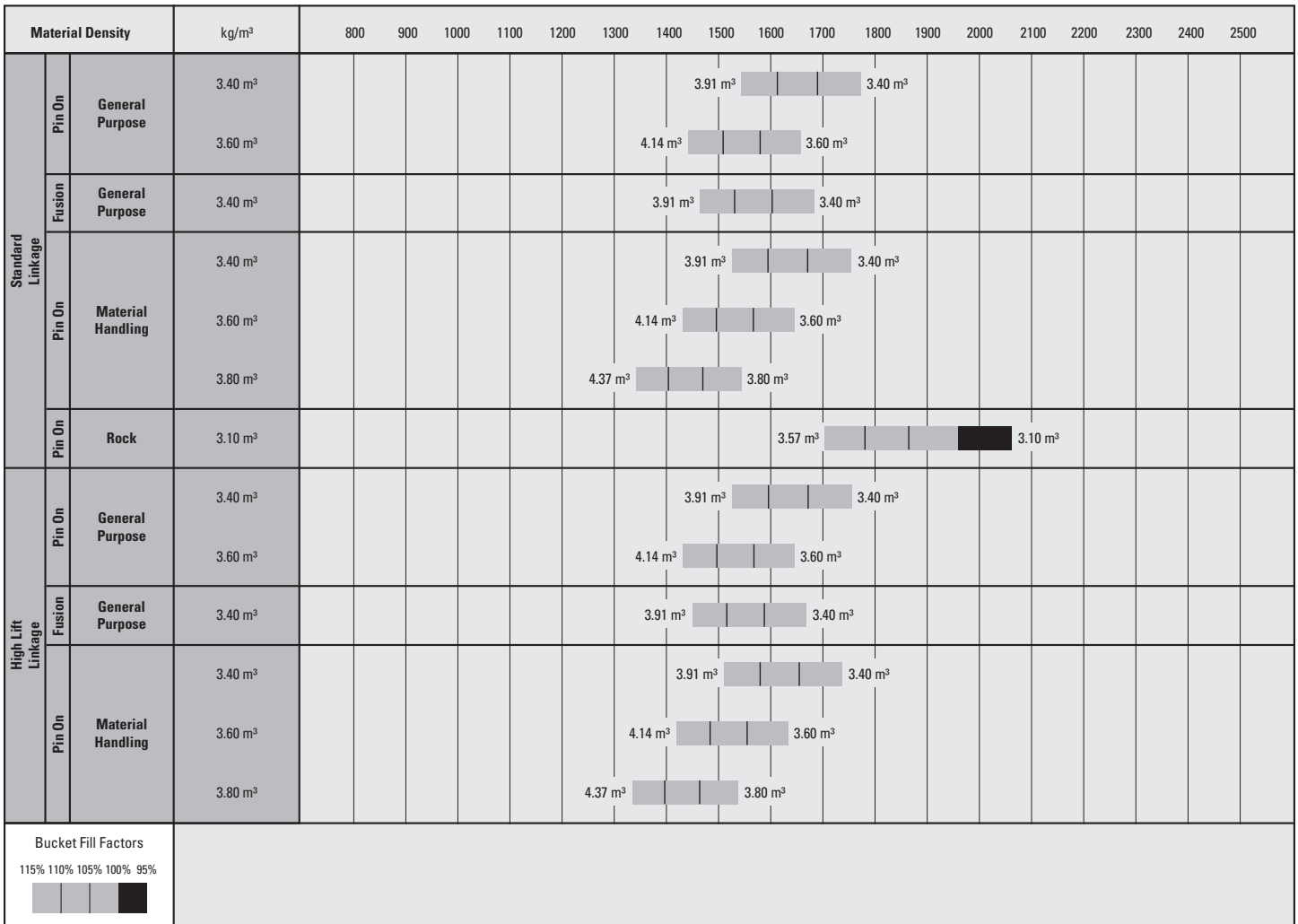

**Note:** All buckets are showing Bolt-on Edges except the Rock Bucket is showing Tips.



# 950L/962L Wheel Loaders Specifications

## 962L Operating Specifications with Buckets

Linkage		Standard Linkage						High Lift Linkage Change*
Bucket Type		General Purpose – Pin On				General Purpose – Fusion QC		
Edge Type		Bolt-On Cutting Edges	Teeth and Segments	Bolt-On Cutting Edges	Teeth and Segments	Bolt-On Cutting Edges	Teeth and Segments	
Capacity – Rated	m <sup>3</sup>	3.40	3.40	3.60	3.60	3.40	3.40	
Capacity – 110%	m <sup>3</sup>	3.74	3.74	3.96	3.96	3.74	3.74	
Width	mm	2927	2994	2927	2994	2927	2994	
<b>16</b> † Dump Clearance at Maximum Lift and 45° Discharge	mm	2981	2862	2935	2816	2939	2820	305
<b>17</b> † Reach at Maximum Lift and 45° Discharge	mm	1321	1431	1357	1467	1357	1467	117
Reach at Level Lift Arm and Bucket Level	mm	2812	2973	2872	3033	2867	3028	305
<b>A</b> † Digging Depth	mm	90	90	90	90	98	98	21
<b>12</b> † Overall Length	mm	8431	8604	8491	8664	8492	8665	485
<b>B</b> † Overall Height with Bucket at Maximum Lift	mm	5719	5719	5777	5777	5738	5738	306
Loader Clearance Circle Radius with Bucket at Carry Position	mm	6764	6848	6781	6866	6780	6866	-2
Static Tipping Load, Straight (ISO)**	kg	13 550	13 410	13 430	13 289	12 933	12 794	-64
Static Tipping Load, Straight (Rigid Tire)**	kg	14 301	14 160	14 183	14 041	13 670	13 529	-83
Static Tipping Load, Articulated (ISO)**	kg	11 640	11 500	11 527	11 386	11 051	10 911	-150
Static Tipping Load, Articulated (Rigid Tire)**	kg	12 397	12 255	12 286	12 144	11 794	11 654	-156
Breakout Force	kN	142	141	136	135	136	135	-9
Operating Weight	kg	19 153	19 261	19 211	19 319	19 632	19 740	1071

† Illustration shown with Dimension charts.

\* Maximum values.

\*\* Static tipping loads and operating weights shown are based on a global machine configuration with Michelin 23.5R25 XHA2 L3 radial tires, full fluids, operator, standard counterweight, cold start, roading fenders, Product Link, open/open axles (front/rear), power train guard, secondary steering, sound suppression.

(ISO) Full compliance to ISO 14397-1 (2007) Sections 1 thru 6, which requires 2% verification between calculations and testing.

(Rigid Tire) Compliance to ISO 14397-1 (2007) Sections 1 thru 5.

Other buckets are available and offerings vary by region. Consult your local Cat dealer for further details.

# 950L/962L Wheel Loaders Specifications

## 962L Operating Specifications with Buckets

Linkage	Standard Linkage				High Lift Linkage Change*	
Bucket Type	Material Handling – Pin On					
Edge Type	Bolt-On Cutting Edges	Teeth and Segments	Bolt-On Cutting Edges	Teeth and Segments		
Capacity – Rated	m <sup>3</sup>	3.60	3.60	3.80	3.80	
Capacity – 110%	m <sup>3</sup>	3.96	3.96	4.18	4.18	
Width	mm	2927	2994	2927	2994	
<b>16</b> † Dump Clearance at Maximum Lift and 45° Discharge	mm	2876	2750	2833	2707	305
<b>17</b> † Reach at Maximum Lift and 45° Discharge	mm	1276	1378	1319	1421	117
Reach at Level Lift Arm and Bucket Level	mm	2872	3033	2933	3094	305
<b>A</b> † Digging Depth	mm	98	98	98	98	21
<b>12</b> † Overall Length	mm	8497	8670	8558	8731	485
<b>B</b> † Overall Height with Bucket at Maximum Lift	mm	5779	5779	5828	5828	306
Loader Clearance Circle Radius with Bucket at Carry Position	mm	6785	6869	6803	6888	-2
Static Tipping Load, Straight (ISO)**	kg	13 315	13 175	13 202	13 062	-64
Static Tipping Load, Straight (Rigid Tire)**	kg	14 053	13 912	13 944	13 802	-83
Static Tipping Load, Articulated (ISO)**	kg	11 429	11 289	11 322	11 181	-150
Static Tipping Load, Articulated (Rigid Tire)**	kg	12 173	12 032	12 070	11 928	-156
Breakout Force	kN	136	134	129	128	-9
Operating Weight	kg	19 204	19 312	19 260	19 368	1071

† Illustration shown with Dimension charts.

\* Maximum values.

\*\* Static tipping loads and operating weights shown are based on a global machine configuration with Michelin 23.5R25 XHA2 L3 radial tires, full fluids, operator, standard counterweight, cold start, roading fenders, Product Link, open/open axles (front/rear), power train guard, secondary steering, sound suppression.

(ISO) Full compliance to ISO 14397-1 (2007) Sections 1 thru 6, which requires 2% verification between calculations and testing.

(Rigid Tire) Compliance to ISO 14397-1 (2007) Sections 1 thru 5.

Other buckets are available and offerings vary by region. Consult your local Cat dealer for further details.

## Standard Equipment

Standard equipment may vary. Consult your Cat dealer for details.

### OPERATOR ENVIRONMENT

- Cab, pressurized and sound suppressed (ROPS/FOPS)
- Viscous mounts
- Rear vision camera within multi-function 18 cm color LCD touch-screen display (*capability for displaying machine status, setting and health parameters*)
- EH controls, SAL (single axis lever) lift and tilt function
- Steering, steering wheel
- Radio ready (entertainment) includes antenna, speakers and converter (12V, 10-amp)
- Air conditioner, heater, and defroster (auto temp and fan)
- EH parking brake
- Beverage holders (2) with storage compartment for cell phone/MP3 player
- Bucket/work tool function lockout
- Coat hook
- Cab air filter
- Ergonomic cab access ladders and handrails
- Horn, electric
- Light, two dome (cab)
- Mirrors, rearview external with integrated spot mirrors
- Post mounted membrane 16 switch keypad
- Two receptacles, 12V
- Seat, Cat Comfort (cloth) air suspension
- Seat belt, 51 mm retractable
- Sun visor, front
- Wet-arm wipers/washers front and rear, intermittent front wiper
- Window, sliding (left and right sides)
- Cab tie-off

### COMPUTERIZED MONITORING SYSTEM

- With following gauges:
  - Speedometer/tachometer
  - Digital gear range indicator
  - Temperature: engine coolant, hydraulic oil, transmission oil
  - Fuel level

- With following warning indicators:
  - Temperature: axle oil, engine intake manifold
  - Pressure: engine oil, fuel pressure hi/low, primary steering oil, service brake oil
  - Battery voltage hi/low
  - Engine air filter restriction
  - Hydraulic oil filter restriction
  - Hydraulic oil low
  - Parking brake
  - Transmission filter bypass

### ELECTRICAL AND LIGHTING

- Batteries (2), maintenance free 1,400 CCA
- Ignition key; start/stop switch
- Starter, electric, heavy duty
- Starting and charging system (24V)
- Lighting system:
  - Four halogen work lights (cab mounted)
  - Two LED stop, turn, tail lights
  - Two halogen roading lights (with signals)
  - Two halogen rear vision lights (hood mounted)
- Alarm, back-up
- Alternator, 145-amp brushed
- Main disconnect switch
- Receptacle start (cables not included)

### CAT CONNECT TECHNOLOGIES

- Link technologies: Product Link
- Detect technologies: rear vision camera

### POWER TRAIN

- Engine, Cat C7.1 ACERT – meets Tier 3/ Stage IIIA equivalent and China Nonroad Stage III emission standards
- Fuel priming pump (electric)
- Fuel/water separator
- Rain caps, engine air intake
- Economy Mode (selectable)
- Transmission, automatic countershaft power shift (5F/3R)
- Torque converter, locking clutch with free wheel stator
- Switch, transmission neutralizer lockout
- Axles, open differential front and rear axles
- Brakes, full hydraulic enclosed wet-disc with Integrated Braking System (IBS)
- Brake wear indicators
- Parking brake, disc and caliper
- Fan, radiator, electronically controlled, hydraulically driven, temperature sensing, on demand

### LINKAGE

- Linkage, Z-bar, cast crosstube/tilt lever
- Kickout, lift and tilt, automatic (adjustable in cab)

### HYDRAULICS

- Hydraulic system, load sensing
- Steering, load sensing
- 2V
- Remote diagnostic pressure taps
- Hoses, Cat XT™
- Couplings, Cat O-ring face seal
- Hydraulic oil cooler (swing out)
- Oil sampling valves

### FLUIDS

- Premixed extended life coolant with freeze protection to –34° C

### OTHER STANDARD EQUIPMENT

- Hood, non-metallic power tilting
- Service centers (electrical and hydraulic)
- Auto idle shutdown
- Fenders, front with mud-flap
- Ecology drains for engine, transmission, and hydraulics
- Grill, airborne debris
- Filters: fuel, engine air, engine oil, hydraulic oil, transmission
- Grease zerks
- Hitch, drawbar with pin
- Precleaner rain cap
- Sight gauges: engine coolant, hydraulic oil, and transmission oil level
- Toolbox
- Vandalism protection caplocks

# 950L/962L Optional Equipment

## Optional Equipment

Optional equipment may vary. Consult your Cat dealer for details.

### OPERATOR ENVIRONMENT

- Cover, HVAC metallic
- EH controls, SAL 3rd function
- EH controls, joystick lift and tilt
  - Additional integrated roller switches for 3rd function
- Filter, carbon fresh air
- Mirrors, heated rearview external with integrated spot mirrors
- Precleaner, HVAC
- Radio, AM/FM/USB/MP3 Bluetooth™
- Radio, AM/FM/CD/USB/MP3 Bluetooth
- Radio, CB ready
- Seat, heated air suspension
- Seat belt, 76 mm retractable
- Roof, metallic
- Steering, secondary
- Sun visor, rear
- Windows, rubber mounted
- Windows, with front guard
- Windows, with full guards front, rear and sides

### ELECTRICAL AND LIGHTING

- Four additional auxiliary halogen cab mounted work lights or
- Two additional auxiliary front HI LED and two additional auxiliary rear LED cab mounted work lights with two LED work lights in the radiator grill and LED front turn signals also includes replacement of the standard four halogen cab mounted work lights with four LED work lights (the standard offering and only roading light available is the halogen roading light)
- Warning amber strobe beacon
- Reversing strobes

### STARTERS, BATTERIES, AND ALTERNATORS

- Cold start – 120V
- Cold start – 240V

### CAT CONNECT TECHNOLOGIES

- Link technologies: VIMS™
- Payload technologies:
  - Aggregate Autodig
  - Cat Production Measurement
  - Printer, Cat Production Measurement
- Detect technologies: dedicated display for rear vision camera, full-time activation
- Machine Security System

### POWER TRAIN

- Axles
  - Automatic front/rear differential locks
  - Axle oil cooler
  - Ecology drains
  - Extreme temperature seals
  - Seal guards
- Fan, VPF (variable pitch fan), automatic and manual control
- Radiator, high debris with wider fin spacing

### LINKAGE

- High lift
- Forestry
- Extended capacity (962M only)
- Quick coupler ready
- Autolube

### WORK TOOLS

- Performance Series buckets
- Fusion quick coupler
- Forks, pallet
- Forks, logging

### HYDRAULICS

- Ride control
- 3rd function with Ride Control
  - Standard linkage
  - High lift linkage
  - Forestry linkage

### FLUIDS

- Premixed extended life coolant with freeze protection to –50° C

### OTHER OPTIONAL EQUIPMENT

- Fenders, roading
- Guard, power train
- Precleaner, turbine
- Precleaner, trash
- Platform, window washing
- Cold weather package
  - Transmission filter bypass
  - Fan pump bypass
  - Jacket water or engine block heater
  - Ether aid ready

### OTHER OPTIONAL CONFIGURATIONS

- Industrial and Waste Handler
- Forestry (950L)
- Port and Harbor (950L)







For more complete information on Cat products, dealer services, and industry solutions, visit us on the web at [www.cat.com](http://www.cat.com)

AEHQ7813 (06-2016)

© 2016 Caterpillar  
All rights reserved

Materials and specifications are subject to change without notice. Featured machines in photos may include additional equipment. See your Cat dealer for available options.

CAT, CATERPILLAR, SAFETY.CAT.COM, their respective logos, "Caterpillar Yellow" and the "Power Edge" trade dress, as well as corporate and product identity used herein, are trademarks of Caterpillar and may not be used without permission.

VisionLink is a trademark of Trimble Navigation Limited, registered in the United States and in other countries.

